

VARA FM 4.0

New features

- The TX DELAY is variable to support different HT's efficiently.
Note - Baofengs testers should make sure the **menu #35** eliminates the TX tail. (STE delay elimination OFF). The Baofeng documentation is confusing. It's not clear on some models if ON eliminates the tail or OFF does.
- Audio equalization has been added to correct issues for some HT's. After transmitting it takes time for the RX to stabilize. Software equalization has been added to VARA FM.
- Instrumentation documented that some transceivers not designed for high-speed digital have poor audio response at low voice frequencies. The VARA FM NARROW mode now avoids their use by shifting the frequency range middle frequency up 200Hz.
- Level 1 NARROW mode has improved weak signal capability by selecting a narrow audio frequency range based on audio instrumentation. This change does not affect performance of level 2 and higher modulation techniques.
- Many hours of testing with the 117 KB "N5TW standard file" in NARROW and WIDE modes in both directions led to improved speed level switching.
- A new monitor function has been added to the VARA FM log to report connections to all stations operating on the same frequency. The VARA log now presents entries in chronological order – latest entries on top.
- S/N ratio information has been added to the RMS Express console and VARA FM log. This will allow stations to determine if their station is setup properly.
- Operation of VARA FM sessions thru voice repeaters is improved.
- Digipeater capability can be optionally enabled on any RMS Express or VARA FM gateway making relay of messages over long distances possible. No license is required for stations operating as digipeater but stations using the digipeater need a VARA license. The software modem is a freestanding program and can be used without Winlink software, if only digipeating is required.
- New Ping feature, to test the digi route.

Digipeater operation

Activating a Digipeater is so easy as writing a call sign in the Digipeater textbox. Now you VARA FM station can work as Digipeater, besides working with RMS Packet, Winlink Express, or freestanding (not connected to any application, only a computer running VARA FM). The digipeater doesn't require VARA license.

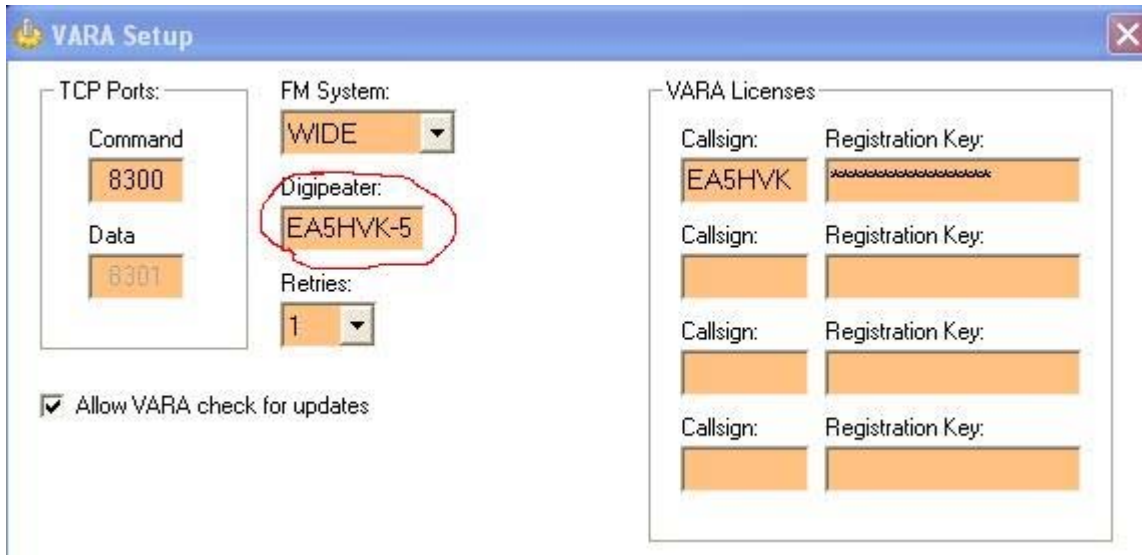

In case of disaster, VARA FM Gateways can lose the internet connection but, activating the Digipeater option, the Gateways located on a mountain could still be useful to create links of 200-300kms

For an easy call sign reminder in case of disaster, Gateway and Digipeater should have the same call sign. The VARA FM protocol design differentiates the Digipeater call sign from the Gateway call sign, even if they are the same.

Also, during a Digipeater connection, the Gateway is OFF. And during the Gateway operation, the Digipeater is OFF. There is no possibility of confusing protocols.

To connect with a VARA FM station using one or two digipeaters you have to select this option in Winlink Express:

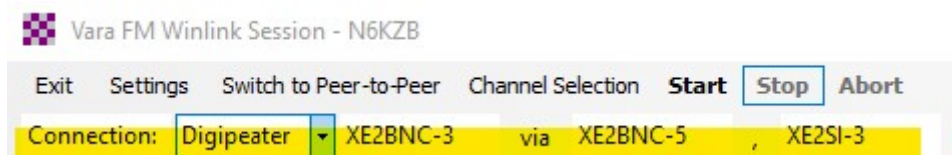

You need a VARA license to connect via digipeaters.

In **VARA Chat v1.2.0** and **VARA Terminal v1.1.2** you have this option ready:

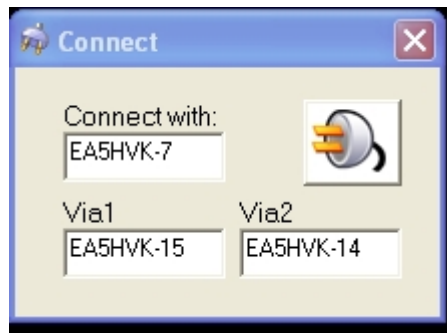

(The file size limit for VARA Chat and VARA FM is **2.048.000 bytes**. Long .PDF files can be sent in the EMCOMM exercises)

Digipeaters are only useful when the direct connection is not possible or the speed is very low. We are talking typically of links of more than 100 kms, or 200-300kms usign 2 hops. But it will depend on each situation, antennas, RF power, mountains, etc...

Autotune and Ping

The sound card window has improved Autotune and a Ping feature, to test the digi route.

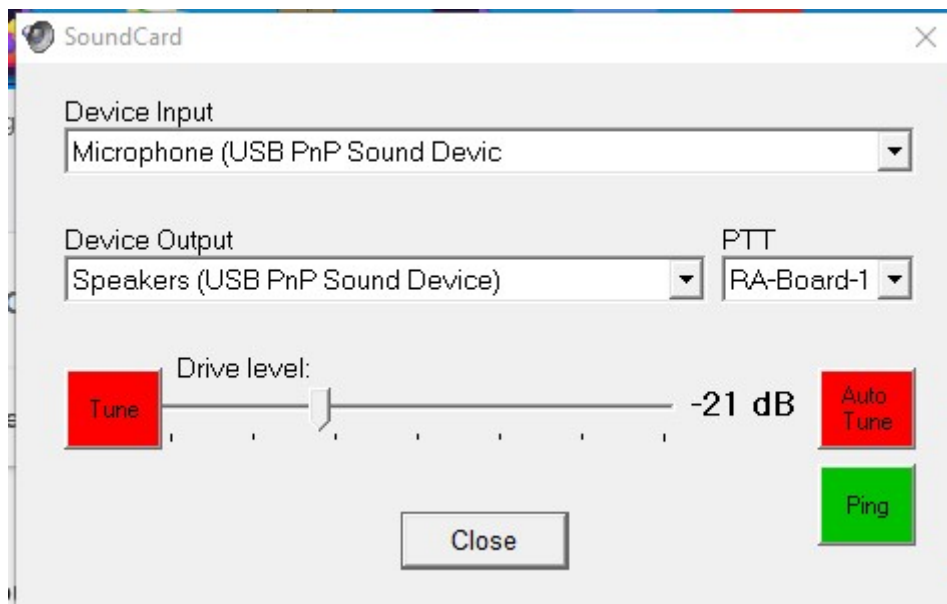

The Autotune adjust automatically the Drive Level but, also, will show a warning message if any level is not right (useful for new users):

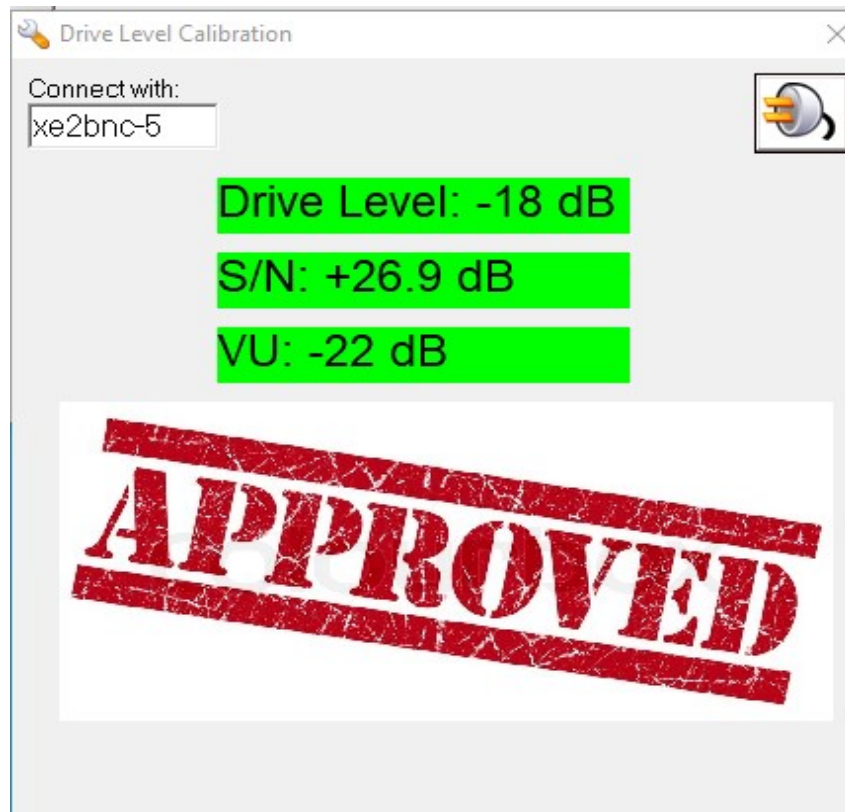

The Ping function show the viability on both directions, either connecting directly, or using digipeaters. In case of digipeaters, the S/N value is the minium along the chain. So, using diferent digipeaters you will have better or worse S/N to reach a same station. The VU levels is useful for monitoring if any station is saturating or has a weak audio input level (below -40dB):

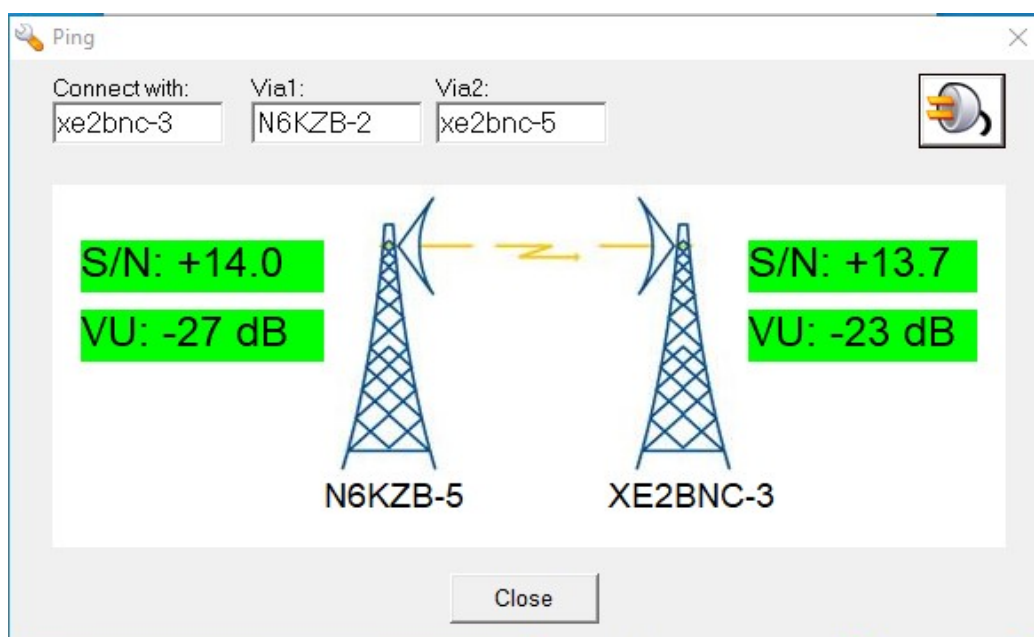

VARA FM Speed Chart

VARA FM v4.0.0 Speed Levels

Level	VARA FM WIDE				VARA FM NARROW			
	Symbol Rate	Carriers	Mod.	Net Rate (bps)	Symbol Rate	Carriers	Mod.	Net Rate (bps)
1	42	14	4PSK	566	42	14	4PSK	549
2	42	29	4PSK	1188	42	29	4PSK	1181
3	42	58	4PSK	2390	42	58	4PSK	2390
4	42	98	4PSK	4040	42	58	4PSK	3188
5	42	98	4PSK	5387	42	58	8QAM	4252
6	42	98	8QAM	7185	42	58	16QAM	5668
7	42	98	16QAM	9580	42	58	32QAM	7087
8	42	116	16QAM	11340	42	58	64QAM	8505
9	42	116	32QAM	14144	42	58	64QAM	9567
10	42	116	64QAM	16932	42	58	128QAM	11162
11	42	116	64QAM	19003	42	58	256QAM	12750
12	42	116	128QAM	22102				
13	42	116	256QAM	25210				

Acknowledgements

Thanks to all the beta testers, and very especially to **Joe AH0A** and **Rick KH7O** for countless ZOOM hours and the whole legion of HT's Hawaii testers.

73

Jose

EA5HVK